

# A NEW APPROACH TO HIGH POWER SWITCHMODE BATTERY CHARGER DESIGN

William Kaewert & Sam Coleman  
Stored Energy Systems LLC  
Longmont, Colorado

## Abstract

Operating at high frequency, switchmode power conversion outperforms line frequency (50 or 60 Hz) power conversion topologies such as SCR and controlled ferroresonant in nearly every way. Switchmode technology delivers advantages in dynamic response, smoothness of DC output, size, weight, noise, energy efficiency, cost, and standards compliance. Switchmode converters are typically modular and hot-swappable, meaning that field repair can be performed faster and by less skilled staff than is required to repair legacy line frequency chargers. Despite these significant advantages, there is continued hesitance by some users, including at electric utilities and some industrial customers, to adopt switchmode technology battery chargers.

This paper attempts to identify the causes for this hesitance. A new approach to the electrical, mechanical and thermal design of switchmode power converters suggests that the issues identified can be addressed. A ruggedized switchmode battery charger design suited for use in challenging environments is presented.

## Introduction

Switchmode power conversion technology dominates nearly every segment of the economy, including demanding aerospace and military power systems that impose requirements more demanding than those imposed by power utilities or industry. Switchmode converters are, for example, successfully hardened against the effects of frequent lightning strikes on aircraft, against the effects of nuclear electromagnetic pulse in warfighting applications, and against the effects of severe vibration and ionizing radiation in launch vehicles and spacecraft. Success in these applications demonstrates two things: first, there is no fundamental impediment to employing switchmode technology in any application; second, that application success depends on the ability of the manufacturer to understand, document, design, and manufacture the product to survive the environmental and performance requirements of the customer's application.

In industrial and power utility applications the reasons for the slow pace of adoption of switchmode chargers seem to include:

- Incompatibility of most switchmode chargers with 480-volt 3-phase AC supplies
- Failure in many cases to sufficiently harden switchmode chargers against AC-borne overvoltage stresses
- Real and perceived problems related to forced, versus convection, cooling

Industrial and power utility facilities often drive large battery chargers with 480 volt, 3-phase electrical service. Most switchmode battery chargers, however, are designed to operate from single phase, 208-240 VAC supplies. Some switchmode chargers are rated for AC input up to 320 volts, potentially enabling them to be employed in a 277/480-volt system by connecting phase to neutral. Switchmode chargers are now becoming available with 480 VAC input that does not require the neutral conductor, and which are compatible with all common 3-phase Delta grounding schemes.

Switchmode converters are inherently more vulnerable to mains-borne electrical transients than line frequency converters. This is because power semiconductors in switchmode converters are located upstream of the converter's power transformer, versus downstream of the transformer in most line frequency designs. This vulnerability can be addressed in switchmode converters by employing the same strategy as that used in aerospace and military systems: multiple layers of defense.

Forced air cooling boosts packaging density and cuts weight and cost in electronic devices. Even with a conversion efficiency of 95% a 7 kW power converter creates 368 watts of waste heat that must be transported from internal components to the environment. Because fans typically fail before power electronics, fans are perceived as an Achilles heel of power converters. The solution employed for years in nearly all higher power UPS and power supplies is to provide redundant fans equipped with failure alarms.

Conventional fan cooling is effective at transferring heat out of densely packaged electronics. The unintended consequence of moving lots of air, however, is the deposition of airborne contaminants onto electronic components and circuit card traces. These contaminants contribute to premature electronics failure. A new method of cooling is presented that reduces the vulnerability of force-cooled electronics to premature failure from atmospheric contamination.

### **How does switchmode differ from line frequency power conversion technology?**

The most popular line frequency (50 or 60 Hz) power conversion technology is silicon controlled rectifier (SCR). SCR type chargers regulate the amount of power transferred from the AC source to the DC output by varying the time the SCR bridge conducts power. The longer during each cycle the SCR bridge is turned on, the more power is transferred. The frequency at which this duty cycle operates is governed by the frequency of the AC power source to which the charger is connected. It is either 50 Hz or 60 Hz.

The size and weight of the charger’s isolation transformer is determined by the frequency of the AC supply. There is a roughly linear relationship between the size and weight of a transformer and its operating frequency. This property enables the use of less iron in the transformer core and fewer wire turns as transformer operating frequency is increased.

Switchmode converters exploit this principle by increasing the frequency at which all magnetic devices in the converter operate. Transformers and inductors in switchmode chargers are vastly smaller and lighter than comparable magnetic components in SCR chargers because the switchmode converter operates at frequencies several hundred times higher than the SCR charger.

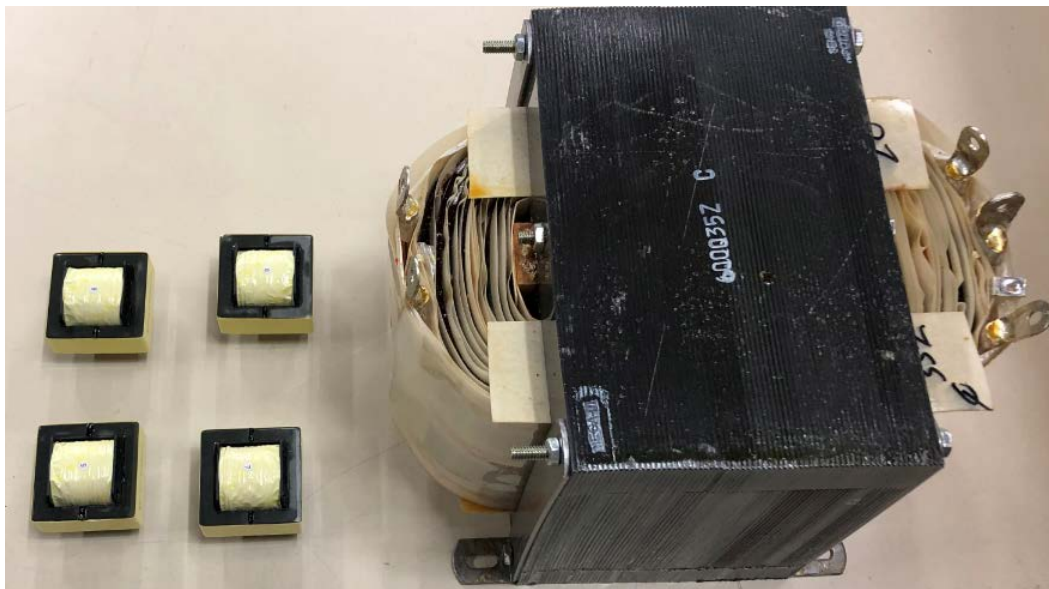

**Figure 1. Switchmode & line frequency transformers for 7 kW charger; 2.7 lb. vs 127 lb.**

## **Incompatibility with 480-volt 3-phase AC supplies**

Most “industrial” (120 & 240-volt DC nominal) switchmode chargers are derived from 48-volt DC telecom type rectifiers that are built in high volume. These chargers can be inexpensive and perform well, provided they are installed in protected environments and supplied with single phase 208 or 240-volt AC. Some single phase switchmode chargers are rated for AC input up to 320 volts, meaning that they potentially could be operated on a 277/480-volt system by employing the neutral. In North America, however, the neutral conductor is only infrequently provided in 480-volt 3-phase systems.

Most industrial facilities employ 480 VAC, typically without neutral, to supply larger loads such as high-powered battery chargers. Some three-phase grounding schemes, such as corner grounding, increase line to chassis voltage stresses on the 480-volt load and require additional insulation between line and chassis. This in turn requires components, including breakers, to be rated for corner grounding. Powering switchmode chargers not natively rated for 480-volt operation from a 480-volt source without neutral requires use of a heavy and costly stepdown transformer ahead of the chargers. Including a 60 Hz stepdown transformer negates much of the weight, size, and efficiency advantages of switchmode technology.

Advances in power semiconductor technology and cost now enable design of switchmode chargers that operate at high voltages. Careful exploitation of these devices allows conversion of 480 volt 3-phase AC to DC exceeding 500 volts or more at efficiencies of 95% and better.

## **Greater difficulty hardening switchmode chargers against AC-borne overvoltage**

Two of the most important types of AC-borne hazards that can harm power converters are electrical transients, such as those caused by lightning, and extreme overvoltage excursion.

### **Overstress damage due to electrical transients**

All power semiconductors (SCRs, diodes, MOSFETs, IGBTs, etc.) are vulnerable to overstress failure when device ratings for voltage, current or temperature are exceeded.

Power semiconductor devices in industrial and utility type battery chargers are subject to voltage overstress damage due to both lightning induced transients and power system switching transients. These events can induce kiloamps and kilovolts onto power converter internal circuitry. These transient energies are modeled and tested using the IEC 61000-4-5 Surge Immunity standard and the IEC 61000-4-12 Ring Wave Immunity standard. Similar waveforms are covered in the ANSI/IEEE C62.41 and ANSI C37.90 standards.

As part of the CE mark for the European Union most equipment is tested to the IEC 61000-4-5 Surge Immunity standard. Several different test levels, however, exist within this standard and there is no guarantee that all equipment with the CE mark is tested against the high surge levels expected in industrial, outdoor, power plant and substation environments. Even IEC 61000-6-5, Immunity for Equipment Used in Power Station and Substation Environments, only requires testing to the higher surge levels for input and output power ports for substation applications. The IEC 61000-4-12 Ring Wave Immunity standard is not required for the European CE mark and IEC 61000-6-5 only recommends, but does not require, ring wave testing.

Regardless of topology, all power electronics employed at industrial sites, power plants and power substations should be designed and tested to the highest published transient immunity levels and should include ring wave testing. If manufacturers do not own the necessary test equipment this testing can be costly, as many third party EMC labs claim that the high stresses of these tests damage their test equipment.

## Line frequency and switchmode designs differ in inherent resistance to electrical transients

Note in Figure 2 below a typical line frequency SCR charger in which the six-pulse rectifier bridge is located on the secondary side of the isolation transformer. In line frequency converters, designers typically exploit a beneficial property of the large 50 or 60 Hz isolation transformer by locating power semiconductors on the secondary side, electrically isolated from the AC source. Transformers operating at these frequencies function as low-pass filters, meaning that they allow power transfer while tending to minimize transmission of high frequency voltage transients typical of lightning strikes.

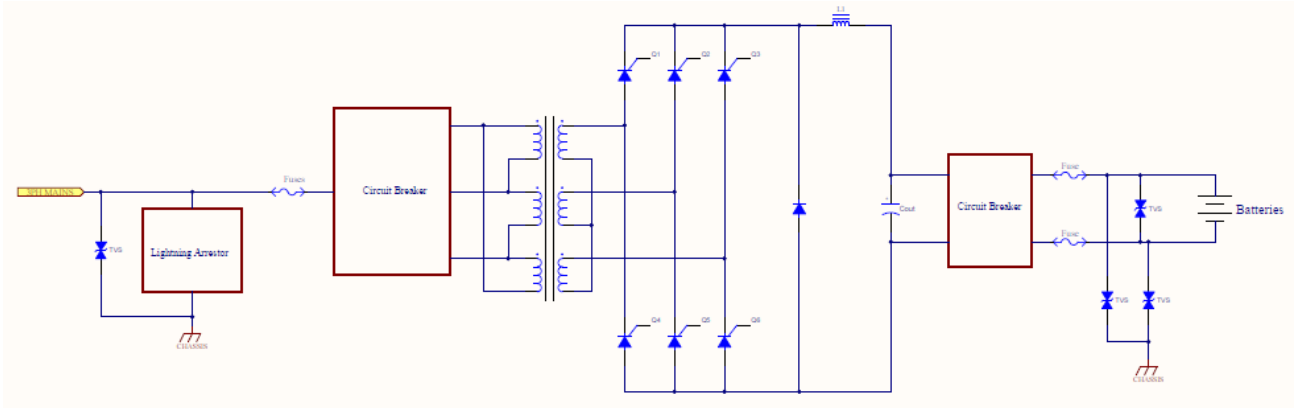

Figure 2. Simplified diagram of 3-phase input SCR type battery charger power train

## Improving electrical transient immunity in switchmode converters

Switchmode designs do not employ 50-60 Hz transformers ahead of power semiconductors. This means that switchmode converters don't natively have the protection afforded by large transformers. But the threat of transient voltage overstress can be mitigated in switchmode converters by applying other solutions. The following describes how multiple layers of electromagnetic protection, validated by both simulation and laboratory testing, enable a switchmode battery charger to survive the most severe standards for electrical transients in industrial and power utility environments.

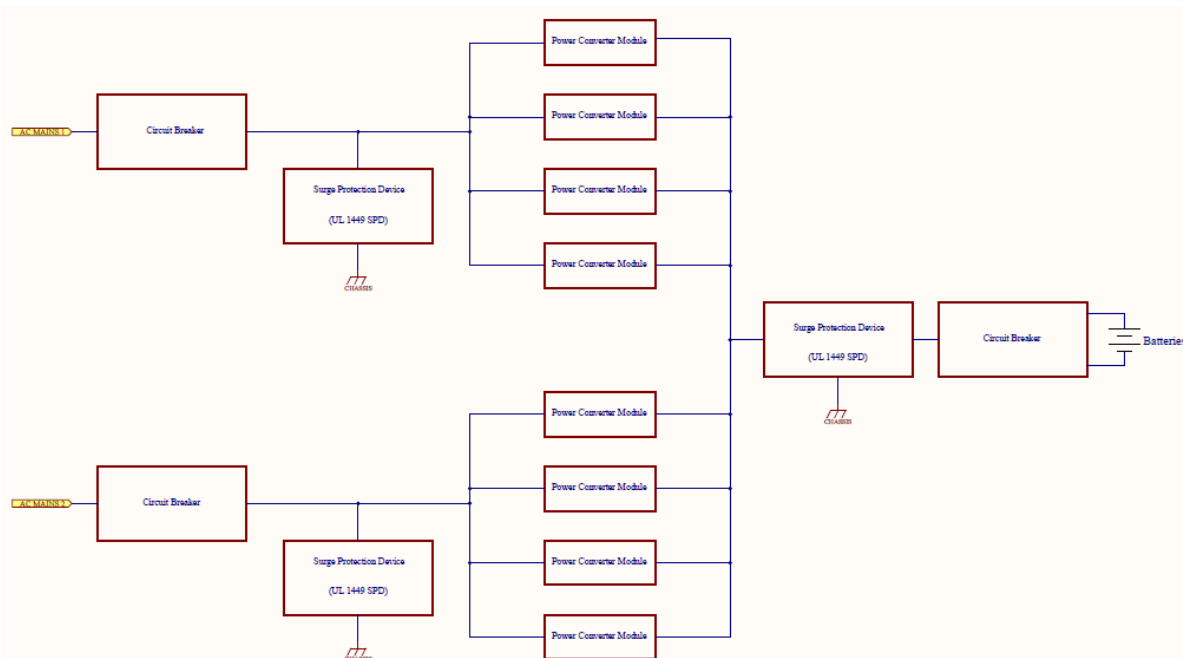
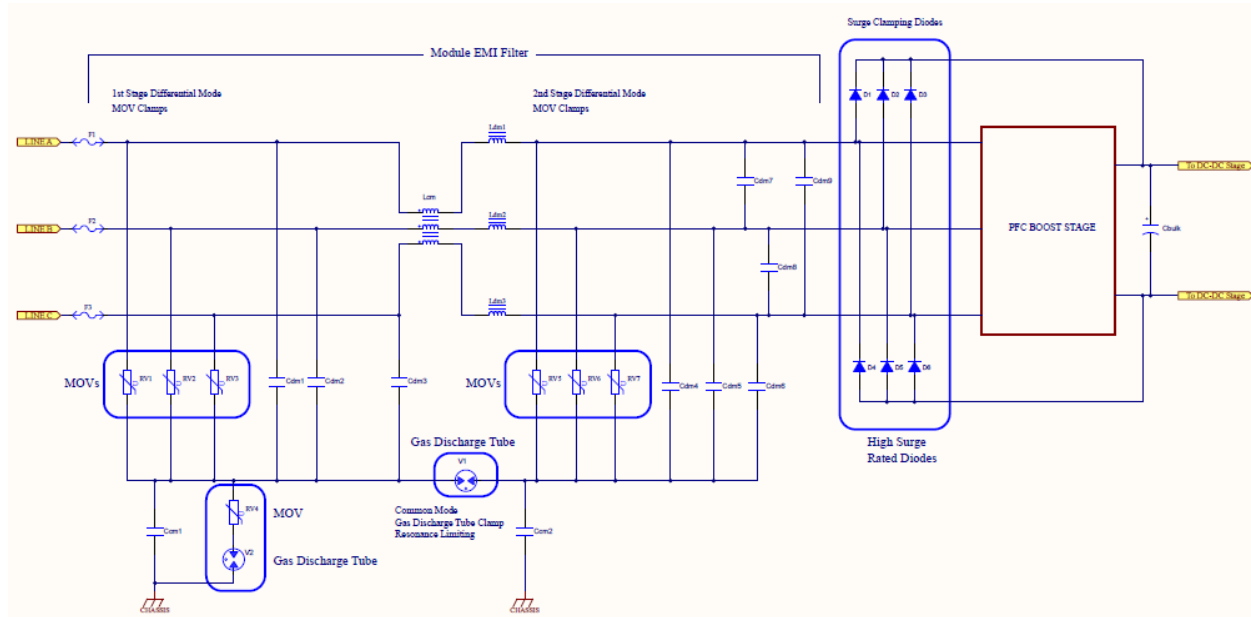

Figure 3. Simplified system-level diagram of modular switchmode battery charger system with dual AC feed

Refer to Figure 3. The first and primary protection layer is field-replaceable cartridge type UL 1449 Listed surge protection connected directly to the charger’s input and output terminals. These replaceable devices offer very high surge current ratings to clamp transient energies at the device terminals. This not only protects the front-end components of the system, including input wiring and connections, but reduces stress on non-replaceable surge protection devices located deeper in the system. Surge protection devices wear out over time, so it is important that these devices are equipped with wear alarm indication, that the alarm is annunciated, and that failed protectors are replaced promptly to ensure a continued high degree of protection. Such surge protection devices must be rated by UL for installation directly on the AC mains and have appropriate circuit protection to meet the requirements of UL 1449.



**Figure 4. Simplified diagram of AC electrical transient protection in a 3-phase switchmode rectifier module**

Refer to Figure 4. In each rectifier module additional metal oxide varistor (MOV) clamps and gas discharge tubes are incorporated into the electromagnetic interference (EMI) filter. MOVs between line and a synthetic neutral provide line to line (differential mode) voltage clamping. An MOV in series with a gas discharge tube located at the synthetic neutral provides line to chassis (common mode) voltage clamping. The MOV in series with the gas discharge tube ensures that the discharge arc is extinguished at the end of the transient even in the worst case of a corner grounded 3-phase system. Additionally, a gas discharge tube is connected between the synthetic neutrals to protect choke windings during surge from insulation breakdown caused by excess voltage. Together, these components protect the EMI filter capacitors and inductors, including clamping transient-induced resonances that would otherwise exacerbate voltage stress.

Figure 4 also shows surge clamping diodes used to provide primary internal protection for power devices. These diodes allow excess voltage to bypass the boost converter circuit such that the excess ends up in the boost converter’s bulk (reservoir) capacitor. This capacitor can safely absorb large amounts of energy, so it is effective at limiting the rise in voltage across phases. MOV and gas tube protectors in the EMI filter described earlier further augment the surge clamping diode system to reduce transient voltage stress on input stage power semiconductors.

During transient events, even well protected circuits endure increased voltage stress. Adequate creepage and clearance distances are essential to preventing insulation breakdown between adjacent circuits. To ensure that spacings are adequate, the appropriate overvoltage category and pollution degree for the application must be selected. In industrial and power utility applications this should include pollution degree 3 and overvoltage category III or higher. Many telecom-based charger designs only employ pollution degree 2 and overvoltage category II.

In addition to the pollution degree and overvoltage category, care must also be taken with general circuit and signal layout. Mixing of power and signal conductors should be avoided and signal loop area should be minimized. Filtered signals should not be adjacent to unfiltered signals. Sensitive signals and high-power circuits should be shielded by Faraday cages whenever practical to protect from internal and external noise and transients. Designs with multilayer PCB boards with ground planes and controlled spacings have inherent advantages over designs using multiple discrete cables where cabling routing and placement are less controlled.

Placing all power electronics inside sealed metal Faraday cages is advantageous for three reasons. Faraday cages provide a high degree of shielding from strong external radio frequency (RF) fields and minimize RF emissions from the converter itself. And, as we discuss shortly, sealed metal boxes prevent dirt and dust from accumulating on circuit traces and on components. This significantly reduces the risk of failure in polluted or high humidity environments.

Employing a multi-tiered approach enables robust, cost-effective protection of the relatively vulnerable underlying electronic components against line-conducted and radiated electromagnetic field-induced voltages and currents.

One of the lessons learned when testing both our own power converters and competing products was that transient protection of DC output and communication ports tends to be less thoroughly addressed than the AC input. The DC output and communication ports of all charger topologies are equally vulnerable. Replaceable external surge protectors should be employed on the charger's output terminals to protect the system from voltage transients. Communication ports should be isolated and protected with appropriate devices such as transient voltage surge suppressors (TVSS). Shielded connectors and cables are also recommended to provide additional common mode protection against voltage transients.

#### **Field failure experience due to transient voltage overstress**

Similar protection systems to those described above are also incorporated in a 450-watt single phase switchmode battery charger **except** that the 450W charger lacks the UL 1449 surge suppressor and Faraday cage.

The field failure rate of this switchmode charger was compared to the field failure rate of an older SCR type charger in the same customer application (engine starting). The comparison examined service records for failures judged to have been caused by over voltage transients. The comparison, performed at the identical total production quantity milestone for each product, shows similar performance of SCR and switchmode technology chargers. The SCR charger failure rate due to lightning was 1.66 per 10,000 units shipped, while the switchmode charger failure rate due to lightning was 1.64 per 10,000 units produced.

**Conclusion:** There appears to be no difference in failure rate due to lightning between carefully designed switchmode and SCR type chargers in the same application and at the same production milestone despite none of the switchmode chargers being equipped with external UL 1449 surge suppression. The substation environment, however, is more vulnerable than the engine starting application to AC mains-borne transient

voltage overstress, and therefore supplemental UL 1449 surge suppression is recommended at substations and in generating stations to reduce risk of transient-induced charger damage.

### **Overstress damage due to long-term AC overvoltage**

There is another way in which switchmode chargers may be more vulnerable to voltage overstress than line frequency chargers: AC voltage excursion above the charger's rated input voltage.

Extreme AC voltage excursion can occur in powerplant environments where the battery charger and other plant auxiliary loads are powered by the plant's own 480 VAC bus. When powerplants shed a large portion of their normal load the voltage internal to the plant increases significantly. One utility engineer stated that the 480 volt bus in some power plants experienced short duration voltage surges to 590 volts for a duration of 30-60 cycles when load of approximately 10% of generating plant output was suddenly dumped. Since many power plants do not regulate voltage supplied to auxiliaries, battery chargers in those plants will be exposed to AC voltages significantly higher than the common battery charger rating of 10% above nominal. This suggests that when located in power plants a 480-volt rated charger needs to survive excursions to 600 volts, and perhaps even higher.

Although standards such as NEMA PE-5 address normal ranges of AC voltages, existing standards do not appear to address the problem of extreme overvoltage excursion described above.

### **Line frequency and switchmode designs differ in inherent resistance to extreme AC overvoltage**

When a line frequency charger is subjected to input voltage 25% above nominal its input transformer saturates. Transformer saturation causes a disproportionate increase of input current with increasing AC voltage. When AC voltage rises high enough the transformer looks like a short circuit. If the saturation event lasts long enough the upstream circuit protection device(s) open. The charger shuts down. Although manual intervention is required to restart, the charger typically does not suffer component damage beyond blown AC fuses.

### **Protecting switchmode converters from extreme overvoltage events**

Switchmode chargers don't include a line frequency transformer ahead of their input stage, meaning we cannot rely on a saturating transformer to block energy transfer or disconnect from the AC source in response to large AC voltage excursions. Power semiconductors in switchmode chargers remain physically connected to AC and therefore are vulnerable to overvoltage damage even if the charger is shut down.

Protecting a switchmode converter from extreme overvoltage in 480 VAC powerplant applications therefore requires rating it to survive nearly 600 volts AC, and automatically disconnecting it from the AC source should extreme AC overvoltage persist at that level or rise above 600 volts. Disconnect should occur when input voltage exceeds some value higher than the charger's normal operating specification, but below the point where damage to charger components occurs. One solution is to employ an AC input breaker equipped with a shunt trip, along with an accurate sensor and current source to trigger the shunt trip. Disconnecting the charger from AC protects the converter in a similar way the line frequency charger would be protected – by disconnection – but at a more predictable AC voltage. As with the SCR type charger, a user would need to reset the switchmode charger's input AC breaker after the extreme overvoltage event has ended.

Automatic reconnection to the AC line would be possible if a contactor and associated power supply and drive circuitry were located ahead of the input breaker.

## Problems related to fan-forced cooling

IEEE 1613 has sometimes been cited as justification for prohibiting cooling fans in power electronics employed at power generation sites and in substations. This standard simply states that, “*Devices meeting this standard shall be convection cooled and shall not include internal fans or any other means of forced air circulation.*”

There are two reasons this argument fails for battery chargers:

1. IEEE 1613 is a standard related to environmental and testing requirements for communications networking devices in electric power substations. It is not a battery charger or power electronics standard. Power utility battery charger standard NEMA PE-5 specifically provides for fan cooling of battery chargers.
2. Three of the four most popular utility charger brands employing SCR power conversion, all of which are installed in both substation and power plant environments, rely on forced cooling of their higher-powered models. Moreover, all three of the most commonly used brands of industrial (not computer room) UPS in power plants employ forced cooling. If end users were reluctant to rely on cooling fans this prevalence of forced cooling would not exist.

Rather than discount the IEEE 1613 prohibition of forced cooling out of hand, we should seek to understand the underlying issues. Solving real and perceived problems might enable many more users to enjoy the significant benefits in size, weight, cost and packaging that forced cooling enables.

### Fan reliability

The first problem with forced cooling is the fan itself. Parts count reliability predictions (e.g. Mil-Std; Bellcore) show that fan failure rates significantly exceed those of electronic components. This also passes the reasonableness test because the fan is the only continuously moving part in most electronic products and therefore has a well-known wear-out mechanism. A charger shuts down when its cooling fan fails either because of component failure from thermal overstress, or because the charger contains protection against thermal overstress that automatically reduces its output power limit to a very low value. Both outcomes are unacceptable in mission-critical applications.

The importance of air filtration to fan reliability must be emphasized. A failure mode and effect analysis (FMEA) for commercial PC cooling fans documents that, “dust is the main cause of the cooling fan failure. This leads to overheating and eventually to loss of the system because of air flow reduction. This cause is due to the fact that the users don’t perform proper and timely maintenance.”<sup>1</sup>

---

<sup>1</sup> *A Failure Mode and Effect Analysis (FMEA) for a Commercial PC Cooling Fan*; Cretu et. al; Acta Electrotechnica, Volume 56, Number 5, 2015



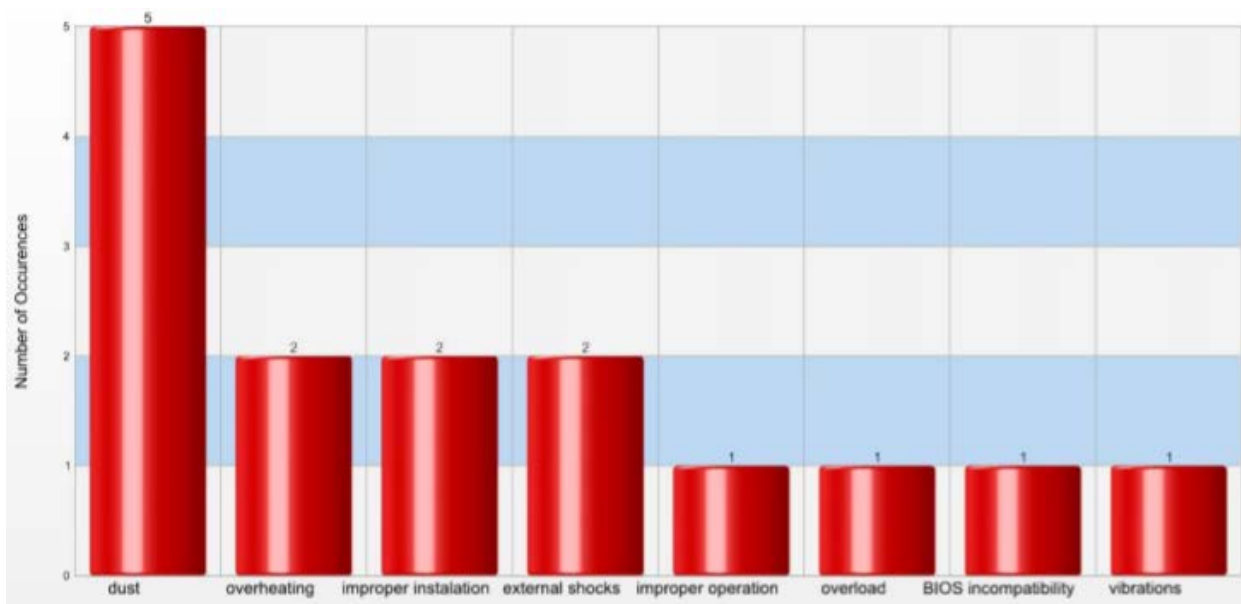

**Figure 5. Leading causes of fan failure in computers<sup>2</sup>**

Although high-powered SCR or switchmode power converters are not computers, the technology of fans, including housing, fan blade, motor, bearing system (including magnetic bearings), PWM drive and wire harness, is more similar than different. Airborne dirt is a problem for all fan cooled systems.

**Fan-forced deposition of atmospheric contaminants onto internal circuitry**

Cooling fans force large quantities of dust, dirt and other airborne matter into the device being cooled. In heavier industrial and outdoor environments, the contamination problem is much worse because these atmospheres can contain corrosives, conductive dirt and salt fog. These contaminants can accumulate quickly on circuit boards and on electronic components, creating two types of failures. Contamination on printed circuits can cause short circuits between adjacent traces and components, causing both intermittent and catastrophic failures. Contamination that accumulates on and around components increases component temperatures by adding a layer of insulating dirt. The resulting temperature increase shortens useful life of components.

Figures 6 and 7 below show two power converters co-located with each other, a VRLA battery and an air compressor in a light industrial facility located in a dry climate. The first photo is of a convection cooled SCR type charger in service for 13 years. Note that only minor accumulation of dirt is evident.

---

<sup>2</sup> Ibid.

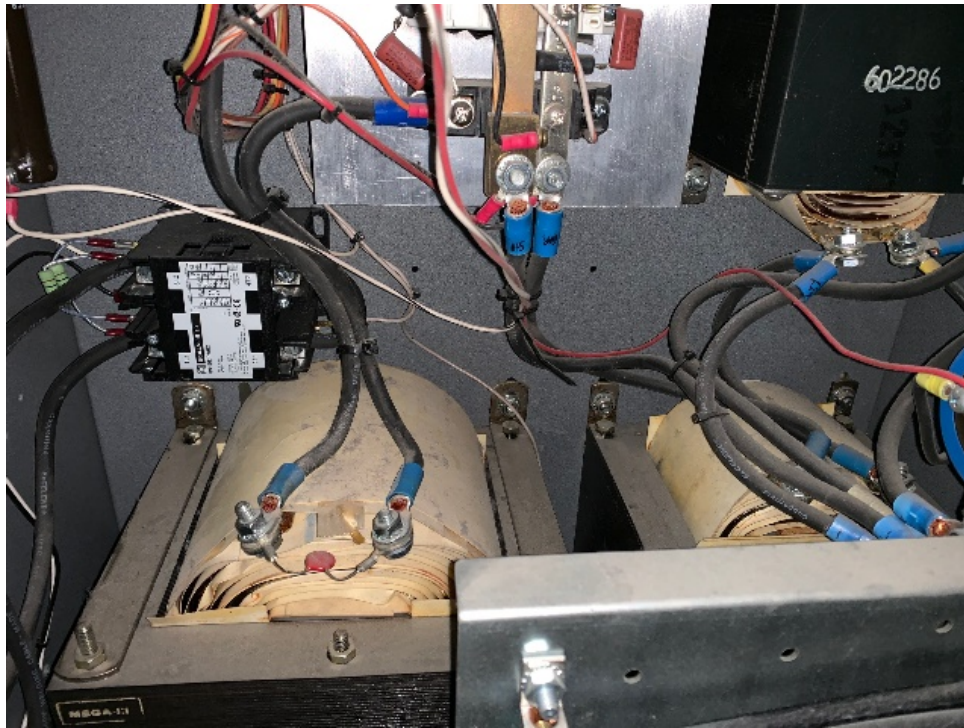

**Figure 6. Minor dirt accumulation inside convection cooled SCR charger after 13 years**

Figure 7 shows the inside of a fan-cooled modular inverter module, taken after about five years of continuous operation. Note the thick dirt buildup of dirt in some areas completely blankets electronic components. The difference in both the amount and rate of dirt accumulation is significant: 13 years for the convection cooled charger, versus five years for the inverter. If the fan-cooled inverter had been in a humid or coastal climate it probably would have failed from dirt-related effects by five years.



**Figure 7. Significant dirt accumulation inside fan cooled inverter after 5 years**

## Summary of requirements for reducing the risk of forced cooling system failure

Improving cooling system performance requires that multiple issues be addressed: reliability of fans; reducing dirt ingress; alerting users to problems; improving serviceability; ensuring user safety; and making the system reasonably resilient against user abuse. The following summarizes performance requirements for a robust forced air cooling system:

1. **Filtration** of cooling air is important both to improving fan life and reducing contaminant buildup in the device being cooled.
2. **Filter properties:** The air filter needs to be effective, inexpensive, reusable, offer reasonably long cleaning intervals, and be easy and safe for non-technical staff to clean.
3. **N+1 fans** are necessary so that cooling performance is maintained should one fan fail.
4. **Fan properties:** high quality, rated for high temperature, employing a premium bearing system, and driven at variable speed, so that fans normally turn at life-prolonging slow speed.
5. A **user-friendly alarm system** is necessary to alert users to the need for filter cleaning, to warn of impending fan failure, and to alert when a fan has failed.
6. The **fan assembly should be easy and safe to replace** when needed, even in power converters that are modular, so that fan failure does not require the converter to be replaced.
7. The design of the system must be **resilient against the failure of users to reinstall filters**. Core electronics need to remain protected against atmospheric contamination when users either neglect to, or choose not to, reinstall the air filter.

## Practical solutions to meeting the forced cooling system requirements

Figure 8 shows a 56 kW battery charger comprises eight 7 kW rectifiers. In the configuration shown, cooling air flow is from front to back.



Figure 8. 56 kW battery charger with multiple rectifier modules

Figure 9 below is a front view of one rectifier module (either 140VDC, 50A or 280VDC, 25A) with washable foam air filter and filter retainer removed. Cleaning this filter is no more difficult than washing the foam air filter found on most small combustion engines. The only requirement is tap water. The filter can safely be removed while the charger is energized without the user risking contact with live electrical or rotating components.



**Figure 9. Front view of 7 kW rectifier, filter, retainer and dead metal**

Figure 10 below shows air exhaust and the fan module. The fan module can be replaced once a hot-swap rectifier is removed from the charger cabinet. Four screws are removed and a small connector is unplugged. Removal of the fan module does not expose the user to energized electrical components inside the rectifier module.



**Figure 10. Rear view of 7 kW rectifier with fan subassembly**

The alarm system includes solid-state sensors to detect problems with the cooling system, including fan tachometers, ammeter and barometric pressure sensors. Indication of cooling system problem is integrated with other system alarms and presented in plain language on the charger status display, via alarm contacts and via network interface.

Figure 11 is a side view of the rectifier module in which power electronics are housed inside of two completely sealed boxes, between which a heat exchanger is located. The box on the bottom side of the heat exchanger contains the charger's three-phase AC boost converter, while the charger's DC-DC converter is in the box on the top side of the heat exchanger. Heat is transferred via conduction from warm components on each of the two circuit cards into the aluminum heat exchanger. Front to back air flow driven by fans transfers heat from the heat exchanger into the environment.

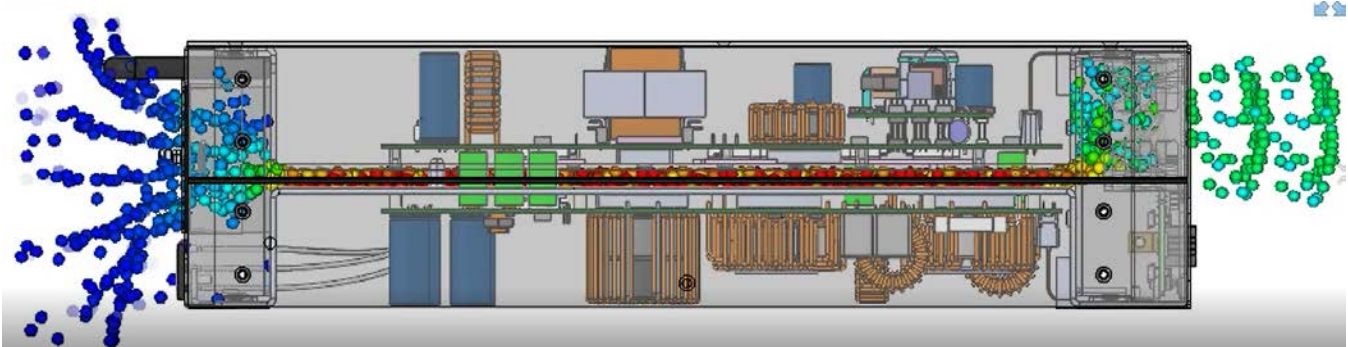

**Figure 11. Side view of air flow isolated from electronic components. Color indicates relative velocity**

Enclosing power electronics in sealed boxes enables several simultaneous benefits:

- High power density is enabled by forced cooling, but without risk of atmospheric contamination of circuit boards and components. This eliminates the problem of premature dirt-induced failures that exist in other forced-cooled power converters. This design protects circuit cards from dirt even when users neglect to reinstall the air filter or choose not to employ the air filter at all.
- Enclosing power electronics inside Faraday cages provides excellent inherent immunity to external radio frequency (RF) fields. The only pathway for ingress of RF is via conduction on input, output and signal connections, protection of which is discussed earlier.
- Converter RF emissions that are inherent to all power converters are contained within the Faraday cages such that despite its high power rating the RF emissions from this design are low.

## Summary

Most switchmode battery chargers for industrial and power utility use have been converted directly from 48-volt telecom power products. A small number of switchmode chargers have improved upon these telecom designs by employing multiple fans and by complying with power utility electrical transient standards. Few existing switchmode chargers operate from 480-volt, 3-phase, 3-wire AC.

A clean-sheet approach to power conversion for battery charging in challenging environments is presented. Central to the design requirements for this new approach are employing 480-volt AC input without requirement for neutral, surviving the electrical and atmospheric contamination environments of industrial and power utility sites, and improving resilience of forced cooling systems.

## Related Questions

### ***Don't the electrolytic capacitors run hot inside the sealed enclosures?***

They do run warmer than if they were directly in the cooling air flow. Life estimates based on capacitor manufacturer's data sheets predict that high specification capacitors will remain within specification longer than ten years when the converter is operated at 100% power, at its maximum full-power rated temperature. Since this duty is more severe than any real-world user would impose actual capacitor life would be longer. A conservative long-term preventive maintenance strategy would include factory refurbishment of rectifier modules, including capacitor replacement, every ten years.

### ***How does the charger handle loss of a phase and brownout conditions?***

When a phase is lost the charger continues operating on a single phase. Current limit is reduced to about half of normal. The 480-VAC rated charger will also operate normally from 208 or 240-volt 3-phase, but with maximum power derated to about half of normal. Brownout shutdown is at around 188 volts.

### ***Why choose a three-phase boost converter versus another topology?***

Nearly all single-phase switchmode chargers includes two stages of power conversion: a boost converter that consumes AC sinusoidally and converts AC to DC, followed by a DC-DC converter that includes the isolation transformer to deliver DC regulated to the correct voltage. The high energy efficiency and unity power factor delivered using this topology are essential to meeting government regulations in most countries and now in the states of California and Oregon. Today these regulations only affect single phase chargers.

In contrast, several topologies are practical for three-phase high frequency rectification. One alternative, for example, is to employ a simple diode three phase natural bridge to supply unregulated DC to the charger's DC-DC converter stage. Although more complex than a three-phase natural bridge, here are reasons to employ a boost converter for the AC stage:

- The boost converter delivers well-regulated DC to the input to the charger's DC-DC converter stage. This enables optimization of the DC-DC converter stage for a single input voltage, minimizing the size and cost of the isolation transformer(s).
- The boost converter presents a low-harmonic, unity power factor to the AC line that some customers specify.
- The boost converter materially reduces input current (by about 28%<sup>3</sup>) below that required for SCR chargers. This enables reduction in sizes of AC input conductor size and upstream circuit breaker. The higher efficiency of the switchmode charger also reduces kW consumption. Assuming a 56 kW charger were continuously loaded to 1/3 its total output, a 95% efficient switchmode design would consume 26 kWh/day less than an SCR unit of the same output. If electricity costs \$0.10/kWh without demand charges, the improved efficiency of the switchmode unit represents \$949 less electric cost per year.
- Government legislators are unpredictable. There is always risk that energy efficiency regulations will be extended to three-phase loads, making older topologies obsolete. The boost converter topology anticipates this possibility, and its existence serves to lower resistance to their imposition because it demonstrates that high efficiency and unity power factor are both possible and cost-effective.
- The boost converter can operate bi-directionally, whereas the natural bridge and some other topologies cannot. Bi-directional operation is valuable because it enables the stacking of storage battery applications and enables greater use of on-site generation. Both developments can improve application resilience, reduce operating expense and increase return on storage battery assets.

---

<sup>3</sup> At 0.75 PF and 90% efficiency an SCR charger requires 83 KVA (100A at 480 VAC) to deliver 56 kW output. At 0.99 PF and 95% efficiency a 3-phase input switchmode charger of the same power output requires only 59.5 KVA (72A at 480 VAC).

## ***What other steps did you take to reduce risk of failure in the power system?***

**Eliminate point-to-point wiring:** The only wires in each rectifier module connect the fans to the fan power supply. All power and control connections are made without discrete wires and wire connections. In contrast, a conventional SCR type battery charger of the same power rating employs approximately 160 discrete electrical connections. Each of these connections is an opportunity for quality failure through either factory workmanship problem, or field failure induced by vibration, corrosion or other problem.

**Effective design & engineering practices:** Risk of field failure of power conversion systems can be reduced by employing multiple different design validation tools, including:

- Applying generous electronic component derating.
- Performing rigorous worst-case analysis in which hardware measurements validate accuracy of component stresses employed in a computer model. The computer model enables simulations to be performed under a wide variety of stresses including “corner case” operations such as simultaneous operations at extreme load, temperature and voltages that are difficult to test.
- Performing normal and abusive testing of hardware.
- Performing ongoing firmware regression testing.

**Modular architecture:** Higher power chargers employ multiple hot-swap modules. This architecture enables N+1 redundancy of power conversion, and enables failures to be remedied by replacement, rather than in-situ repair. Repair by an unskilled staffer can be achieved in just a few minutes by plugging and replacing the affected module. Users are not exposed to hazardous voltages or rotating machinery when swapping modules.

**Split AC and/or DC bus:** Modular architecture enables use of dual AC feeds, such that a single charger can be fed from different AC distribution systems. Employing independent sources reduces the risk of grid failure shutting down all charging capacity. Figure 3 shows 50% of the installed charger capacity fed from one AC source, while the remaining capacity is fed from a different AC source. DC output can also be split into two buses.

**Re-use of proven technologies:** Even though mechanical design of this converter is novel, the core electronics design and software benefit from heavy re-use of field-proven technologies. The basic topology, power device drive software and protection schemes, charging algorithms, alarm system, software and communications software are largely common with a smaller, single-phase switchmode power conversion platform in high volume serial production for three years. Such recycling of proven technologies cuts development time, project risk and field failure risk.

## ***What are related reliability issues with both electronics in the utility sector in general?***

Technology advancements and increasing production volumes have improved the reliability of modern hardware such that other issues common to all topologies of battery charger and other electronic equipment, like software and cyber security, are becoming more significant threats to system uptime than hardware reliability.

### **Software**

Today’s power devices and design tools are more capable than those available even a decade ago. Skilled design engineering combined with high speed computing platforms such as digital signal processors (DSP) cut the risk of power device overstress and related failure. Firmware control over modern platforms enables enormous flexibility in operation, enabling hardware to be employed in a wider variety of applications (e.g. either charger or inverter) than single-purpose products. This means higher volume production per platform. The design standardization and learning-curve effects that accompany high volume production almost always enable higher quality products than lower-volume specialty products with equivalent capability.

As control over battery chargers and other electronic products becomes increasingly digitized the risk of product and application failure shifts from hardware to software. All modern battery chargers regardless of topology are software controlled. Compared with old analog products, firmware and software control enables superior features, performance and cost.

Software-controlled products also encourage automated final test and other processes. It is possible and even advantageous for computers to control final test, burn in, configuration to customer order, labeling, serialization, shipment, and data-archiving. In many cases the regression testing of the product’s firmware and test software is also computer-controlled.

These shifts to software-controlled product, validation and production significantly increase complexity for manufacturers.

Lower hardware cost and more function make products easier to sell. What’s not to like? The shift to software requires manufacturers to devote significant organizational resources to software validation and testing. This is costly because software validation is more difficult to perform manually and much more difficult to simulate and worst-case analyze than hardware. As the nearby chart shows, the back-end costs to both customers and manufacturers of underinvestment in software validation is extreme.<sup>4</sup>

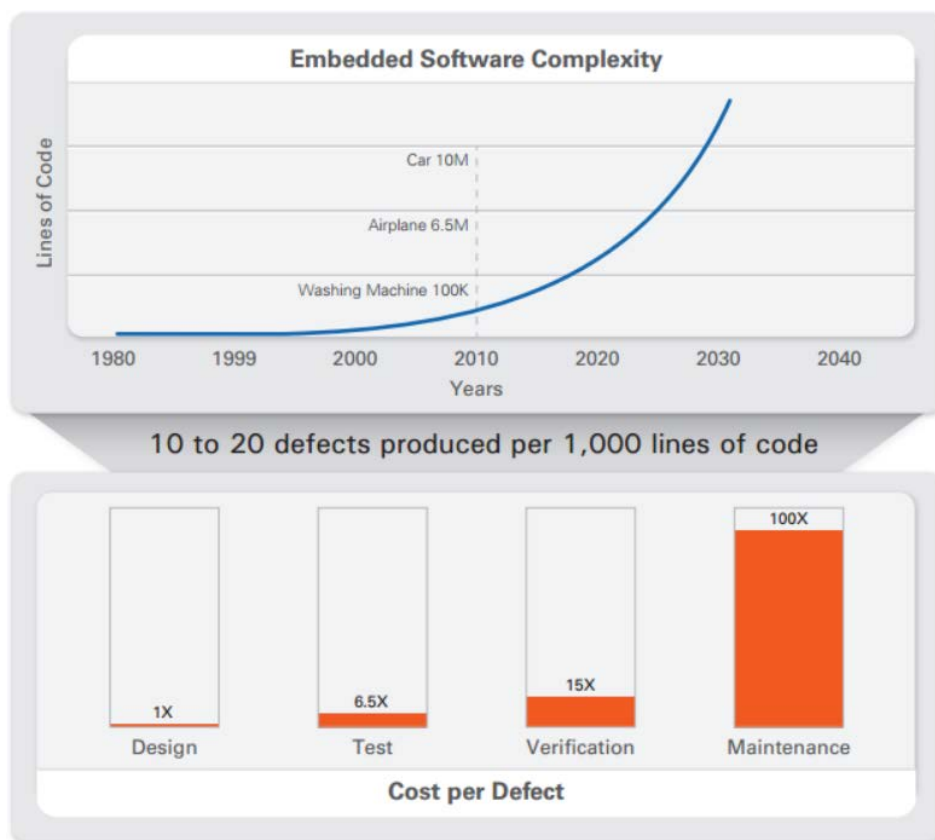

**Figure 12**  
**Growing Problem of Embedded Software Complexity<sup>5</sup>**

<sup>4</sup> Source: National Instruments Corporation, *Solving the Problem of Growing Embedded Software Complexity with HIL and LifeCycle Management*, December 19, 2015

<sup>5</sup> Ibid.



In the power electronics sector, including industrial and utility battery chargers, risks to reliable operation are shifting from hardware into software. The question is no longer whether SCR, controlled ferro, or switchmode chargers are more reliable. Now that all these designs are software-controlled a more appropriate question might be, “which organizations are most effective at developing, managing, validating, controlling, maintaining, and updating software?”

### **Cyber vulnerability**

Cyber vulnerability is closely related to software complexity. This is relevant to battery chargers and power electronics because a) chargers are now networked into power utility operations and, b) there is growing anecdotal evidence that the entire supply chain to power utilities is being targeted for malware attack to harm utility companies that are hardening their own defenses.

**Networked hardware:** Power utility networks increasingly employ networked communication protocols such as DNP 3.0 and IEC 61850 to improve situational awareness of power systems. Networking increases convenience and control. The flip side of this convenience is high risk of widespread and very fast damage to the networked system should it be penetrated. Malware intrusion (including by hostile nations) into power utility control systems has been public knowledge for over a decade. When such malware is activated the results can be catastrophic, as the popular press has documented.<sup>6 7</sup> “What the hackers who created Crash Override did was create modules specifically to exploit electrical systems based on several IEC standard protocols (e.g., IEC 60870-101, IEC 60870-104, IEC 61850). This allowed the hackers to ‘open circuit breakers on [remote terminal units (RTUs)] and force them into an infinite loop, keeping the circuit breakers open even if grid operators attempt to shut them. This is what causes the impact of de-energizing the substations,’ according to the report summary.”<sup>8</sup> “Drago and ESET (cyber security consulting firms) said Crash Override is extensible, ‘and with a small amount of tailoring, such as the inclusion of a DNP3 protocol stack, would also be effective in the North American grid.’”<sup>9</sup>

**Power utility supply chain:** Reliability Coordinators for the North American electric grid and lower level operations control centers rely heavily upon vendors to supply and support complex equipment and firmware.

For simultaneous or near-simultaneous infection or takeover of control systems, a well-regarded vendor which services many clients in critical infrastructures is an ideal target of early-stage attacks. Three primary vendors supply key operating equipment and software for about 80 percent of the major electric transmission companies.<sup>10</sup> And there are dozens of smaller vendors supplying critical grid equipment.

In 2017, Russian hackers penetrated hundreds of electric utilities in a widespread and long-running campaign to cause grid blackouts on command. Some of these utilities were protected by so-called air-gapping and others had firewall protections. So how did the hackers succeed? By first compromising the networks of trusted

---

<sup>6</sup> *Inside the Cunning, Unprecedented Hack of Ukraine’s Power Grid*, Wired Magazine, March 3, 2016;

<https://www.wired.com/2016/03/inside-cunning-unprecedented-hack-ukraines-power-grid/>

<sup>7</sup> ‘Crash Override’: The Malware That Took Down a Power Grid, Wired Magazine, June 12, 2017;

<https://www.wired.com/story/crash-override-malware/>

<sup>8</sup> *Alleged Russian Cyberweapon Knocks Out Power Grids*, Electronic Products Magazine, June 20, 2017;

<https://www.electronicproducts.com/Programming/Software/Alleged-Russian-cyberweapon-knocks-out-power-grids.aspx>

<sup>9</sup> Ibid.

<sup>10</sup> Source: Foundation for Resilient Societies, Nashua, New Hampshire

suppliers with “remote access” to grid equipment.<sup>11 12</sup> Remote access is commonly used for firmware updates, equipment health monitoring, and other service enhancements.

Chinese hackers, often units of the People’s Liberation Army, have used similar techniques.

The targeting of a vulnerable power utility supply chain, with the ultimate goal of damaging power grid operations, is a familiar element of the strategy of information warfare. It is no exaggeration to state that the North American utilities industry and its suppliers are already engaged in a daily war for electric grid security. Our country and our industry should learn from these early skirmishes.

## **Bibliography**

IEC 61000-4-5: Electromagnetic compatibility (EMC) - Part 4-5: Testing and measurement techniques - Surge immunity test

IEC 61000-4-12: Electromagnetic Compatibility (EMC) - Part 4-12: Testing and measurement techniques - Ring wave immunity test

ANSI/IEEE C62.41: IEEE Recommended Practice on Characterization of Surges in Low-Voltage (1000 V and Less) AC Power Circuits

ANSI C37.90: IEEE Standard for Surge Withstand Capability (SWC) Tests for Relays and Relay Systems Associated with Electric Power Apparatus

IEC 61000-6-5: Electromagnetic compatibility (EMC) - Part 6-5: Generic standards - Immunity for equipment used in power station and substation environment

UL 1449: Standard for Safety Surge Protective Devices, 4<sup>th</sup> Edition

NEMA PE-5-1997 (R2003): Utility Type Battery Chargers

IEEE 946: IEEE Recommended Practice for the Design of DC Auxiliary Power Systems for Generating Stations

IEEE 1613: IEEE Standard Environmental and Testing Requirements for Communications Networking Devices Installed in Electric Power Substations

DNP 3.0: 1815-2010 - IEEE Standard for Electric Power Systems Communications -- Distributed Network Protocol (DNP3)

IEC 60870-104: Telecontrol equipment and systems

IEC 61850: Communication networks and systems for power utility automation

---

<sup>11</sup> *GandCrab Ransomware Gang Infects Customers of Remote IT Support Firms*, February 24, 2019; <https://www.zdnet.com/article/gandcrab-ransomware-gang-infects-customers-of-remote-it-support-firms/>

<sup>12</sup> *America’s Electric Grid Has a Vulnerable Back Door—and Russia Walked Through It*, The Wall Street Journal, January 10, 2019

Byrne, J. Allen, "Is it Time To Take a Serious Look At Convection Cooled Switchmode Mode Rectifier/Chargers Again", Battcon 2018

Nasrat, et. al., "Switch Mode Battery Chargers for Utilities: Why? How? And Where?", Battcon 2014

Ma, Janet, "Component Reliability in Photovoltaic Inverter Design", Schneider Electric, 2013

Burke, Mary, "Why and How to Control Fan Speed for Cooling Electronic Equipment, Analog Dialogue 38-02, February 2004

Xiaohang, et. al., "Physics-of-Failure Analysis of Cooling Fans", Prognostics & System Health Management Conference, 2011

Persons, et. al., "Battery Charger Technologies", Battcon 2014

Kapler, et. al., "PV Inverter Performance and Reliability: What is the Role of the IGBT?", Sandia National Laboratories, Albuquerque NM