

# The case for continuous remote monitoring of DC power plants

By  
Joe Rocci and Walter Wilczewski  
Phoenix Broadband

## Introduction

Batteries have been and will continue to be an ever increasing part of our lives. Whether in our cars (conventional and electric hybrid vehicles), in backing up enterprise data systems, telecommunications infrastructure, or as part of building management systems, the demand for back up power (and batteries) is growing and will continue to do so for the foreseeable future. During emergency situations such as natural disasters and blackouts, or simple e911 mobile calls, back-up power reliability is becoming critical. Along with many other industries, today's Telecommunications and mobile operators can't afford to gamble on battery backup! To ensure back-up power systems can perform as expected when required, a comprehensive understanding of the battery's operating condition, or "state of health", and history are critical. Antiquated manual quarterly maintenance practices are insufficient to provide enough information to ensure continuous reliability. What is necessary and long overdue, are reliable, standards-based, real time remote monitoring systems which can provide accurate on demand information (not just data). These new systems will gather data, analyze it and provide mechanisms for intelligent analysis, which can alert operators to pending battery problems and help, determine how back-up systems will perform when needed.

## Battery Basics

Fact: As batteries age they lose their ability to deliver power. According to the "IEEE Std 450 2002" document, when a battery has lost 20% of its rated capacity it is no longer viable (or predictable) and should be replaced. Battery capacity is typically measured in Amp/hours which is a battery's rated ability to deliver a specific amount of power using a given load for a specific period of time.

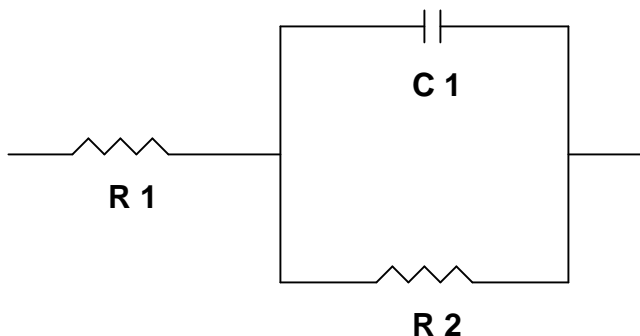

Figure 1

Figure 1 shows is an example of a very simple lead acid battery model which can be thought of as a set of series resistances in parallel with a capacitor. Where R1 represents resistance of metals and electrolyte, R 2 represents the "Charge transfer resistance" (The ability of cell to

accept a charge which reduces as the electrolyte becomes saturated near the electrode/electrolyte interface region<sup>1</sup>) and C1 is the total battery capacitance which is typically 1.5 farads per one hundred Amp/hour capacity. In a lead acid battery R2 represents no more than about 40% of the DC resistance. Therefore, most of the battery's impedance will be determined by metallic resistance, and capacitive reactance variations<sup>2</sup> (though charge transfer resistance will also play some part).

## **DC Load Testing**

A “battery” is a DC power source made up of one or more electro-chemically based voltage generating “cells”. As mentioned above, each cell has internal resistances that limit the amount of current the cell can supply to the load. In addition to a cell's pure DC properties, it also exhibits characteristics of a large capacitor. The effect of this capacitance on battery testing methods will be discussed later.

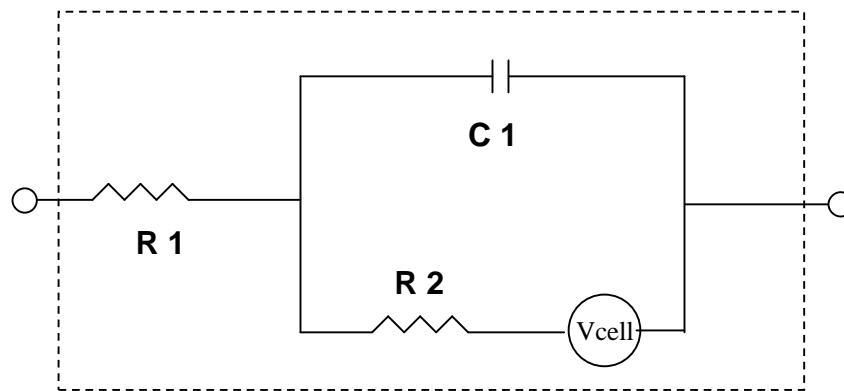

If the equivalent cell circuit above were analyzed by drawing a short-circuit DC current from its terminals, the capacitive component would not come into play because the currents are pure DC, and the cell would deliver a maximum current determined by Ohm's law:

$$\mathbf{I = E/R}$$

where I is the maximum current the cell can supply, E = Vcell and is a voltage determined by the internal electro-chemical construction of the cell, and R=R1+R2 and is the combination of all resistances inside the cell.

As an example, an ideal lead-acid cell with a chemistry-determined cell voltage (Vcell) of 2.2V and an internal resistance (R1 + R2) of 0.001 ohms would deliver a maximum instantaneous short-circuit current (Iss) of:

$$\mathbf{Iss = Vcell/(R1+R2)}$$

$$\mathbf{Iss = 2.2/.001 = 2200 \text{ amps}}$$

<sup>1</sup> (A review of battery charging algorithms and methods)

<sup>2</sup> (The Virtues of Impedance testing of batteries)

The terms ‘maximum’ and ‘instantaneous’ are used here because, from the moment the load current begins to flow, the cell begins to lose charge, causing the internal resistances to increase, causing the voltage at the terminals to drop, causing the current to decrease.

A traditional test to determine the ‘‘amp-hour’’ capacity of a cell is called ‘‘resistive load testing’’, and consists of the steps of connecting a moderate to heavy resistive load of known value to the cell and determining how long it takes for the cell’s terminal voltage to drop by a specified amount. This type testing, though informative & effective, is also time-consuming and destructive. If the cell is called upon to deliver power shortly after this type of discharge test is performed, it might not have sufficient charge remaining to deliver the expected run-time. Because of the limitations and destructive nature of resistive DC load testing, an advanced & minimally intrusive alternative called ‘‘impedance testing’’ has been developed and proven effective.

## ***Dynamic AC Testing***

Impedance testing is a method that forces a small (usually under an amp) AC test signal into the battery’s terminal posts and measures the small terminal post AC voltage component caused by that current. Impedance testing is also governed by ohms law, except that the voltages and currents are AC voltages and AC currents. Using very small AC test results in very small AC signal voltages, but small AC signal voltages are easily separated from the cell’s large DC component by use of AC coupled voltage amplifiers.

An example of an AC impedance test setup is shown below:

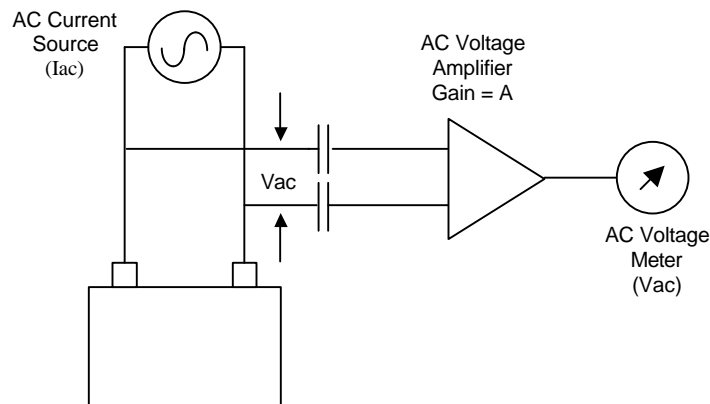

In this example, if we assume the same cell properties referenced earlier (but ignore the capacitive component), then the internal resistance of the cell is  $R = R_1 + R_2 = .001$  ohm. If the test signal generator develops a current  $I_{ac} = 1$  amp through the battery, then the terminal post voltage (V<sub>cell</sub>) will also have an AC component (V<sub>ac</sub>) superimposed upon it. According to Ohm’s Law:

$$\mathbf{E = I \times R \text{ so,}}$$

$$\begin{aligned}V_{ac} &= I_{ac} \times R \\V_{ac} &= 1.0 \times .001 = .001 \text{ VAC}\end{aligned}$$

This resultant AC voltage on the battery terminals is clearly very small and would be very difficult for a normal measurement instrument to resolve in the presence of the much larger  $V_{cell}$  voltage of 2.2V, but we can solve that problem by using an AC coupled voltage amplifier which does not respond to the very large  $V_{cell}$  DC voltage. If we assume that the AC amplifier has a voltage gain of 1000, then the signal at the amplifier output would be 1VAC, which is easily measured. A simple arithmetic manipulation can be used to relate the measured AC voltage at the amplifier output to the internal resistance of the battery.

### ***What About the Capacitance?***

The above AC measurement example would be a precise indicator of the battery's internal cell resistance except for the matter of the cell capacitance and its affect on the AC measurements. The cell capacitance is a function of the amp-hour capacity of the cell, and is usually estimated to be about 1.5 Farad for each 100 amp-hours of cell capacity. At high AC test frequencies, the AC reactance of this capacitance could be small enough so that it would 'mask' the value of the  $R_2$  component of the battery resistance by effectively shorting it out. For this reason, impedance measurements are commonly performed at very low frequencies where the capacitive reactance is not significant compared to the resistance that it shunts ( $R_2$ ). Frequencies well below 50 Hz are typically used.

In any case, the value of the cell's internal capacitance is also correlated to amp-hour capacity, and so tracking the combined cell's relative impedance (which is the combined effect of resistance and capacitance) over time is very useful in determining changes in the cell's state of charge, even if the absolute impedance measurements are not 100% accurate.

### ***Battery Failure modes***

Batteries are designed with a life expectancy of a specified number of years. The actual life span of a Lead Acid battery is greatly dependant upon its operating environment (including battery temperature, charging voltage, and to a lesser extent the number of discharge/charge cycles) and mechanical performance (deterioration of internal connections and proper valve operation). In my discussions with operators in the Telecom, Wireless, and CATV industries the general consensus is that these batteries do not always meet the designed life expectancy. Common reasons for failure to meet design life expectancy are:

- Improper float charging (which can cause excessive gassing and eventual dry out)
- Excessive ambient temperature ( IEEE 450 2002 estimates 50% loss of life expectancy for an eight degree C or 15 degrees Fahrenheit, temperature rise above 25 degrees C or 77 degrees F)

- Deterioration of straps, grids, and post connections due to corrosion, sulphation or mechanical failure
- Thermal runaway

## ***Present Preventative Maintenance Practices***

Currently operators practice either a “rip and tear” time based battery replacement strategy or performs quarterly (semi-annual or longer) interval testing to determine when to replace batteries. In today’s environments many stationary VRLA batteries will only last from three to eight years. Replacing batteries too early is inefficient and costly while waiting too long can cause unwanted loss of power to critical services. **Time based battery replacement is simply gambling with system availability!**

Existing preventative maintenance testing practices consist of two types of manual testing at different periodic intervals. At “quarterly” intervals testing of batteries typically consists of measurements (at least voltage and AC impedance/Conductance) taken with a hand held meter combined with checking mechanical connections and a visual inspection. At intervals of one or two years operators perform (either a rate adjusted or time adjusted) load tests to determine the capacity of each battery in the DC power plant. Load testing is a good method for determining the battery’s state of health but is intrusive, time consuming and expensive. Operators with hundreds or thousands of locations to test would likely find load testing an untenable approach. Also, load tests should not be performed within 72 hours of a battery discharge event.

AC impedance/Conductance testing is considered non-intrusive and can uncover battery irregularities. Though Impedance/Conductance testing has some minor inherent measurement inaccuracies including manufacturer’s stated reference value, and measurement repeatability (with different meters and technicians) this method has been proven to be a reliable barometer. Any accuracy errors can easily be overcome when measured with a single device, at the same measurement point, and trended over many data points and time. However these inaccuracies can be misleading if only a few measurements per year are performed as with quarterly manual testing permits.

Operators who perform manual preventative maintenance would like to adhere to IEEE 450 recommended practices however many of the tests which are now performed quarterly are in fact recommended by the IEEE to be performed monthly. Intervals at which so called “quarterly” testing is performed can actually be as long as five month intervals (if testing is done early in one quarter and late in the next). According to a number of operators with which we have talked, batteries can and do fail in between the testing periods. This manual testing methodology is at best only partially effective especially if/when budget considerations also affect the regularity of preventative maintenance testing.

After manual tests are performed, the information is gathered and typically manually transferred to log files and subsequently to spreadsheets or other software programs.

This approach however is problematic in that it:

- Is primitive in nature
- Does not provide real time battery status,
- Its information is not readily available to all appropriate personnel
- Provides little or no compiled historical information
- Does not provide enough statistical data to show accurate trends
- Will likely miss battery failures

## ***Remote Monitoring***

### **Past**

In the past remote monitoring of batteries has not been widely considered because of cost and complexity.

Though the idea was enticing there were obstacles to overcome. Including:

- Basic communications links to remote sites,
- PC based systems (several of which required a PC at each location)
- Slow speed of serial communications
- Expensive and complex proprietary hardware and software
- Primitive data gathering systems which produced alarm storms yet provided little intelligent information.

### **Present**

New technology and standards have dramatically reduced the cost and complexity of remote monitoring. These obstacles are no longer a gating factor. In the Telecommunications industry SNMP is fast becoming the network management protocol of choice and many operators have network managers in place which support SNMP. A wide variety of options for providing remote TCP/IP communications links are readily available at very reasonable costs. Intelligent web based hardware/software programs which are designed specifically to monitor battery performance and can easily scale are now available. These systems not only provide real time battery status, but show historical trend analysis, parameter correlation, and intelligent alarming.

Continuous remote monitoring is the best way to determine the comprehensive state of battery health. Today's standards based new technology platforms provides operators with:

- Real time visibility of enterprise DC power plants and UPS
- Reduced maintenance costs
- More efficient use of resources during crises events
- Proactive vs Reactive maintenance
- Means for automating data gathering
- Intelligent processing and analysis of gathered data
- Historical trend data
- Consistent measurement practice

- Alarm notification and routing
- Standards based platform and

## **Summary**

The addition of new services will increase demands on operators for system availability which will require more reliable battery back up systems. Competition is forcing operators to reduce operation costs. To cope with these forces operators may re-think today's manual maintenance practices as it has proven at best only partially effective. Continuous remote monitoring provides a comprehensive and effective means of assessing battery health. Continuous remote monitoring also provides operators a means for being more effective with resources and to proactively perform maintenance as necessary. The combination of standards and new technology has finally brought forth intelligent low cost battery monitoring systems which can quickly, continuously and automatically gather and analyze data from thousands of remote sites. The result is greater system availability, lower operations costs and ultimately happier customers.

## **Bibliography**

- IEEE 450 2002 Recommended Practice for Maintenance, Testing, and Replacement of Vented Lead-Acid Batteries for Stationary Applications
- Measurement of Impedance and Conductance: Myth and Reality Tested in the Field (H. Dupendant, R. Ferger)
- Impedance/Conductance Measurements as an Aid to Determining Replacement Strategies (M Kniveton British Telecom, A.I. Harrison Chloride Industrial Batteries Limited)
- VRLA Battery Monitoring Using Conductance Technology (Intelec 95)
- Battery Impedance Monitoring...An Added Dimension (Gary Markle)
- Don't Gamble on Your Battery Backup (Steven Dworkin)
- Some Field Experience with Battery Impedance Measurement as a Useful Maintenance Tool (J. M. Hawkins Telstra Research Labs)
- The Virtues of Impedance Testing of Batteries (Rick Lawrence, George Esmet, Pete Merl, JC Heyneke Megger)